

<b>ATK SPACE SYSTEMS, INC.</b>			
LOS ANGELES, CALIFORNIA			
PROPELLANT TANK ASSY, OXIDIZER			
CAGE CODE	SIZE	DWG NO.	REV.
18229	E	80405	E
SCALE: 1/2	SHEET		1 OF 3

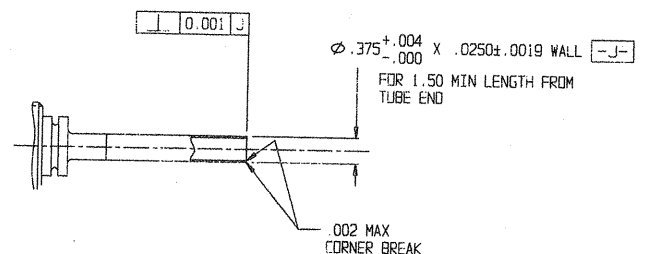
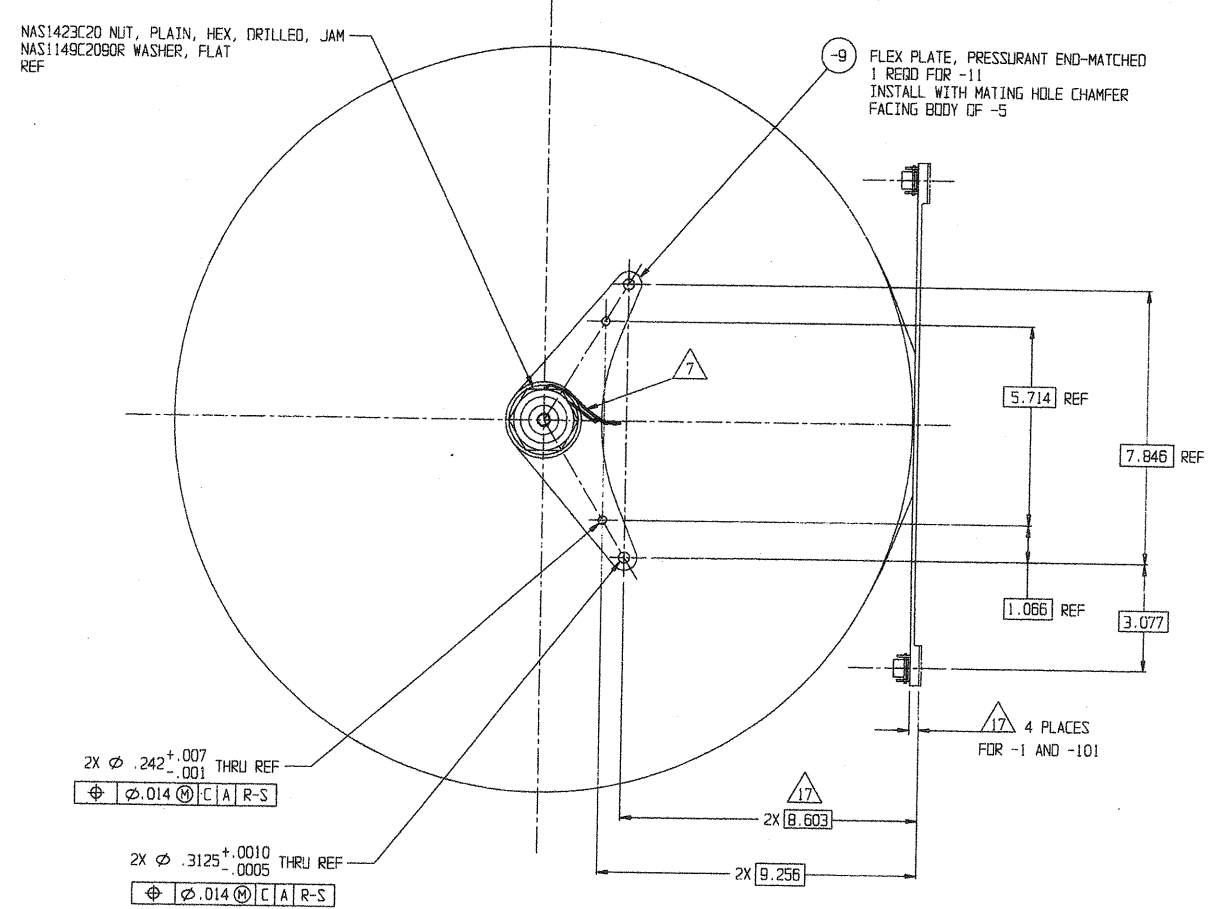
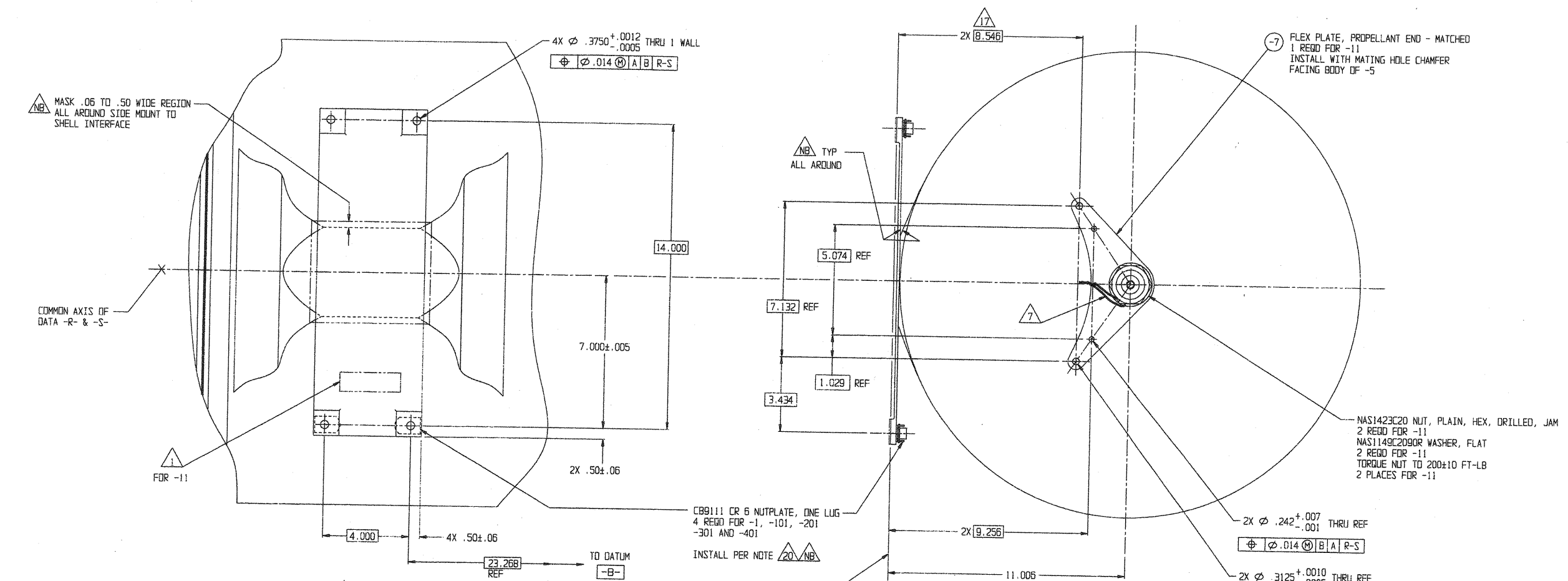

VIEW X-X SHEET 1

VIEW Y-Y SHEET 1

VIEW E SHOWN FOR -1, -101, -201, -301 AND -401 SHEET 1

VIEW F OPPOSITE FOR -1, -101, -201, -301 AND -401 SHEET 1

SCALE: 1/1

**ATK SPACE SYSTEMS, INC.**  
LOS ANGELES, CALIFORNIA

PROPELLANT TANK ASSY,  
OXIDIZER

CAGE CODE	SIZE	FIG. NO.	REV.
18229	E	80405	D

SCALE: 1/2 SHEET 2 OF 3

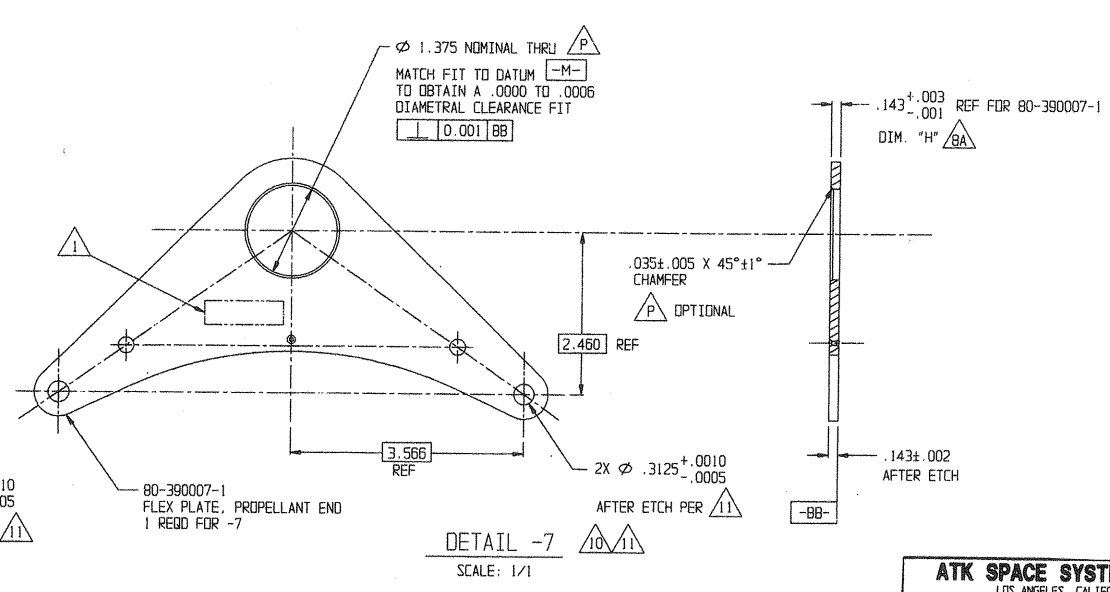
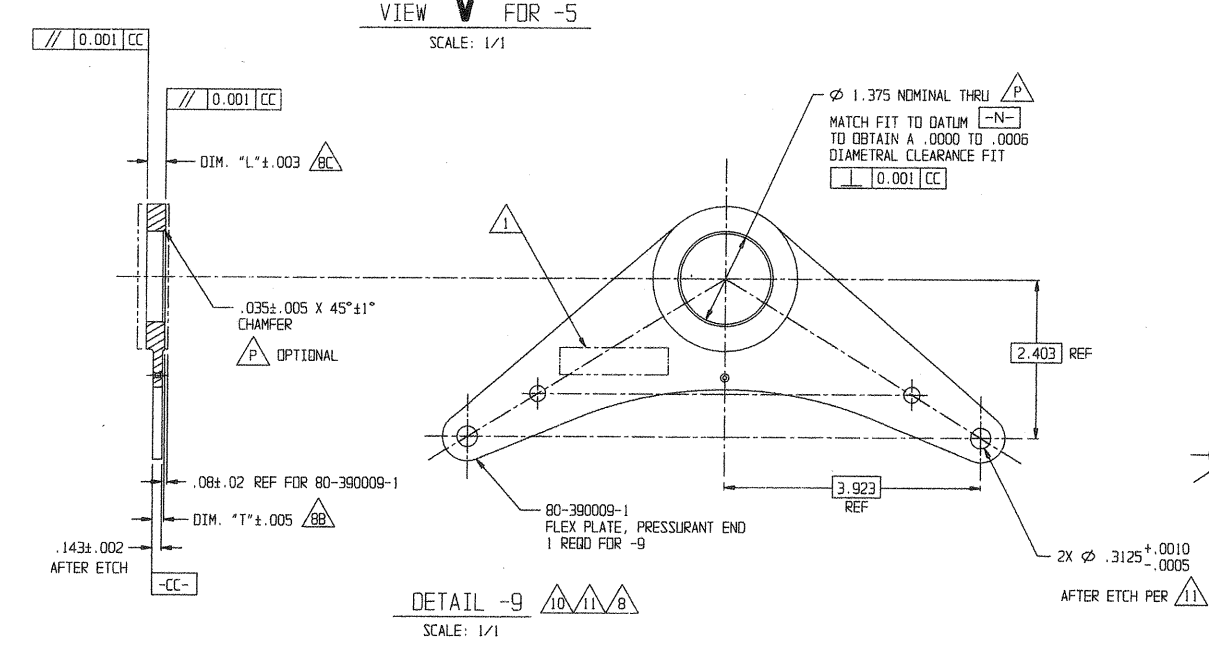
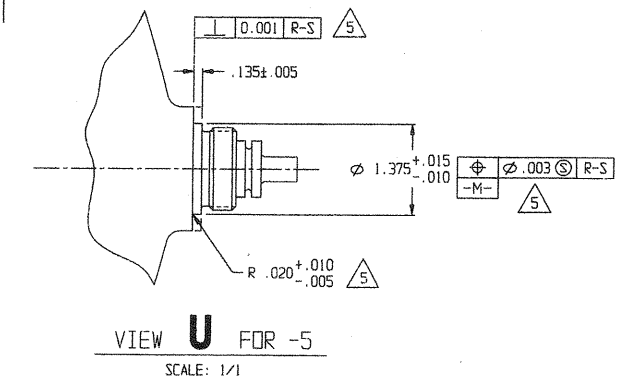
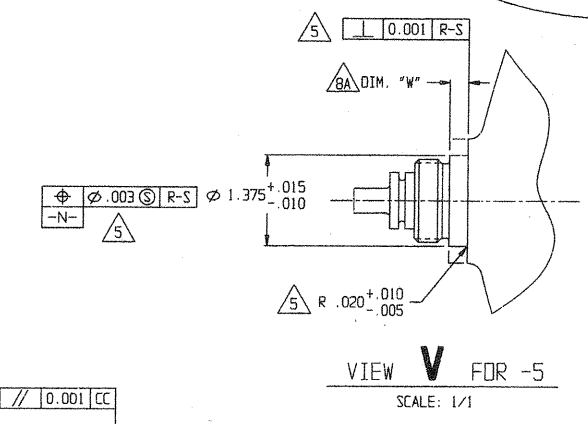
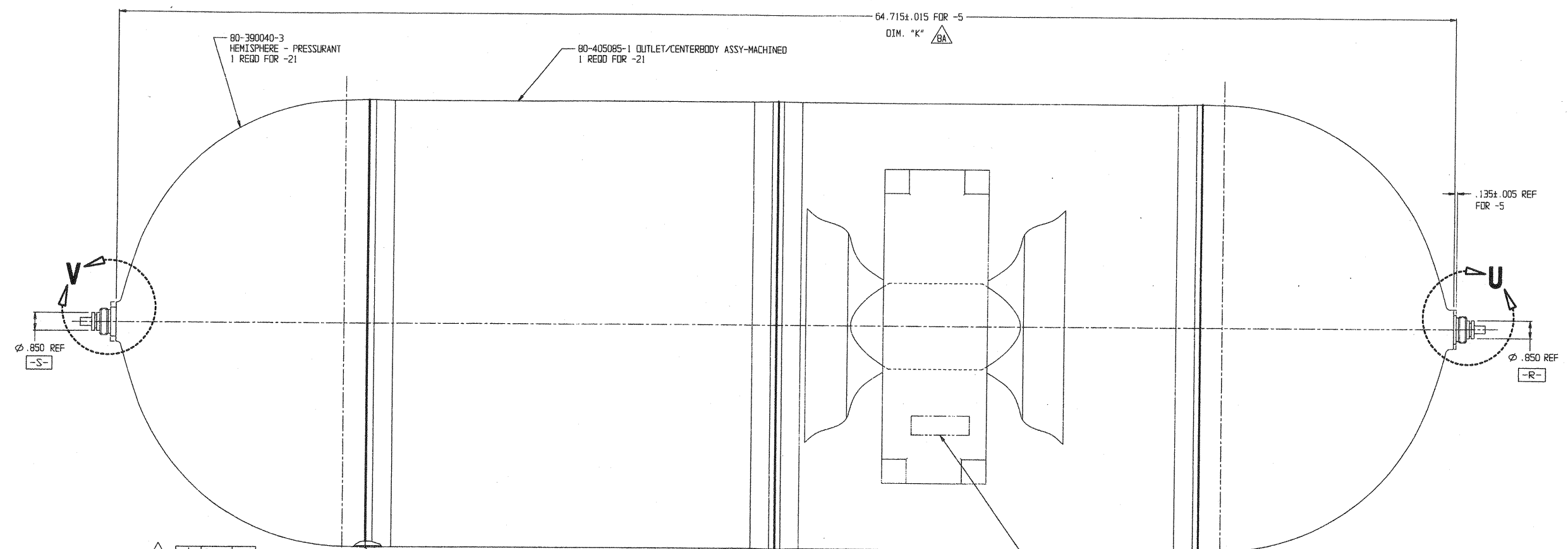

<b>ATK SPACE SYSTEMS, INC.</b>			
LOS ANGELES, CALIFORNIA			
PROPELLANT TANK ASSY, OXIDIZER			
CAGE CODE	SIZE	ENG. NO.	REV.
18229	E	80405	C
SCALE: 1/2	SHEET	3 OF 3	