

PRESSURE SYSTEMS, INC.			
LOS ANGELES, CALIFORNIA			
PROPELLANT TANK ASSY			
CAGE CODE	SIZE	DWG NO.	REV.
18229	E	80470	B
SCALE: 1/4		SHEET 1 OF 3	

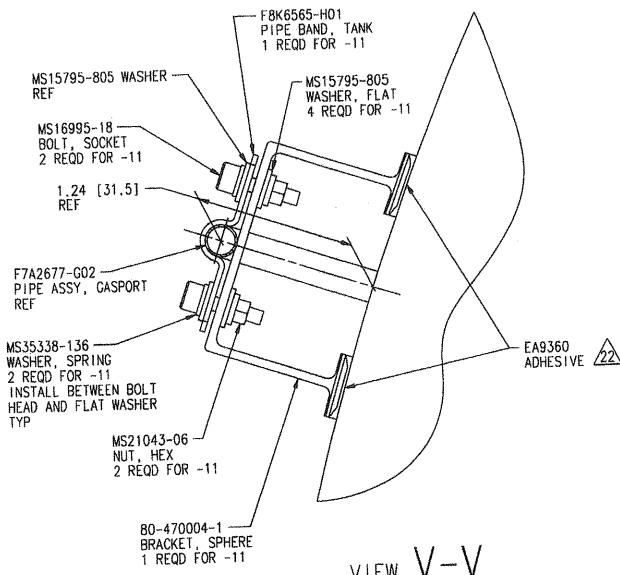

VIEW V-V  
 PARTIAL BACKGROUND OMITTED  
 FOR CLARITY  
 SCALE: 2/1

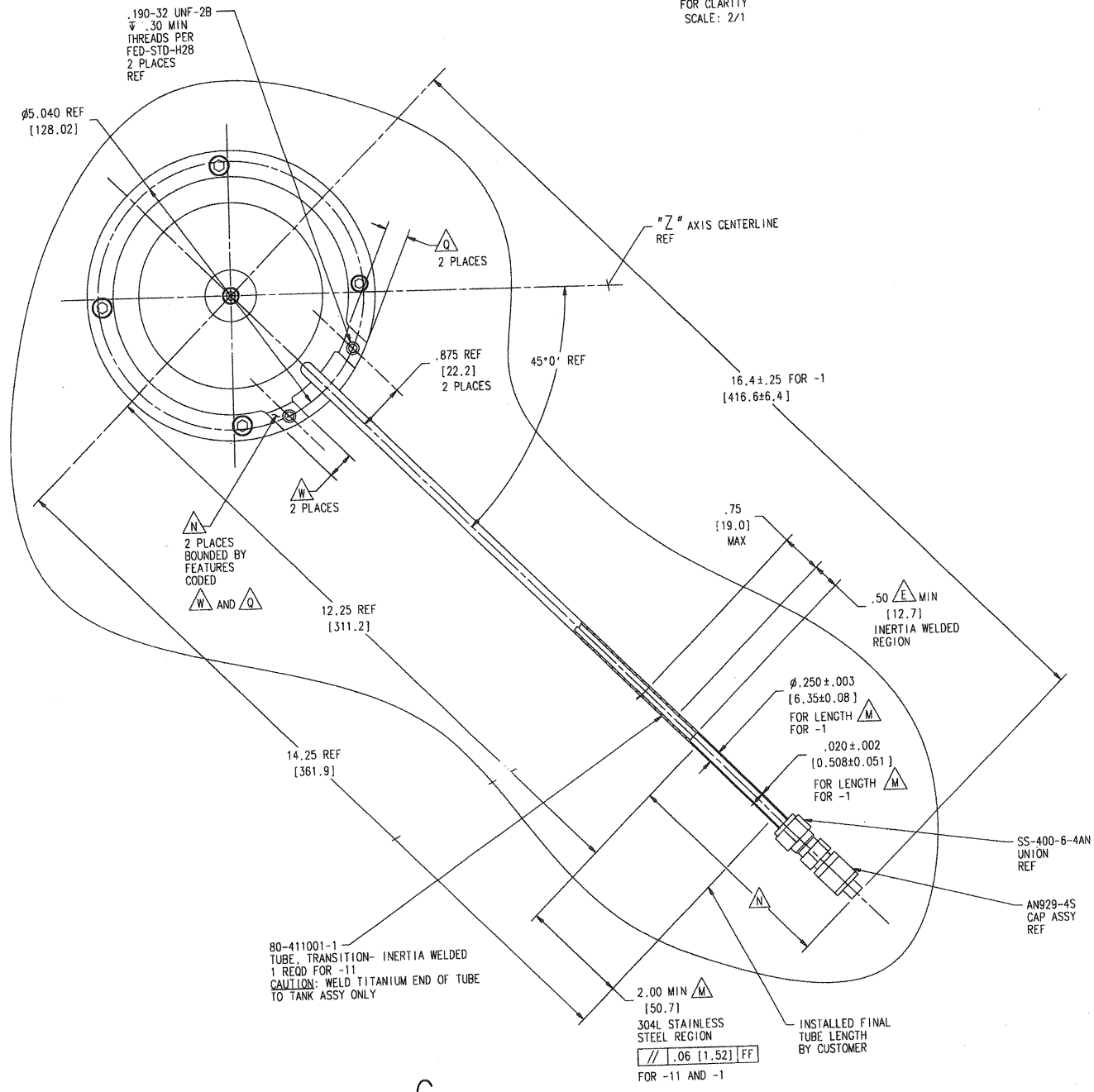

VIEW G SHEET 1

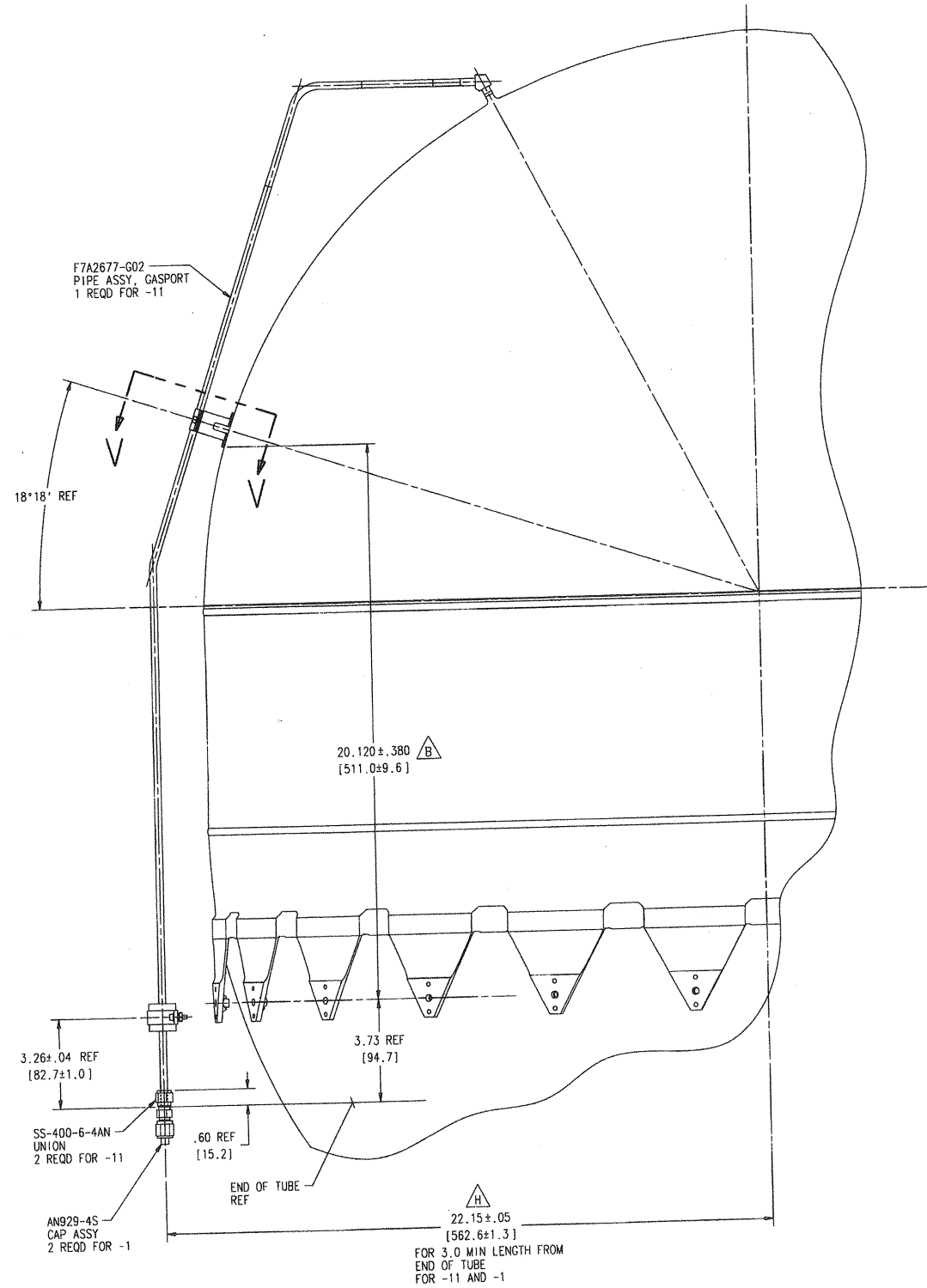

VIEW K-K SHEET 1  
 ROTATED 7°30' COUNTERCLOCKWISE  
 SCALE: 1/2

<b>PRESSURE SYSTEMS, INC.</b> LOS ANGELES, CALIFORNIA			
<b>PROPELLANT TANK ASSY</b>			
CAGE CODE <b>18229</b>	SIZE <b>E</b>	DWG NO. <b>80470</b>	REV. <b>B</b>
SCALE: 1/1		SHEET 2 OF 3	

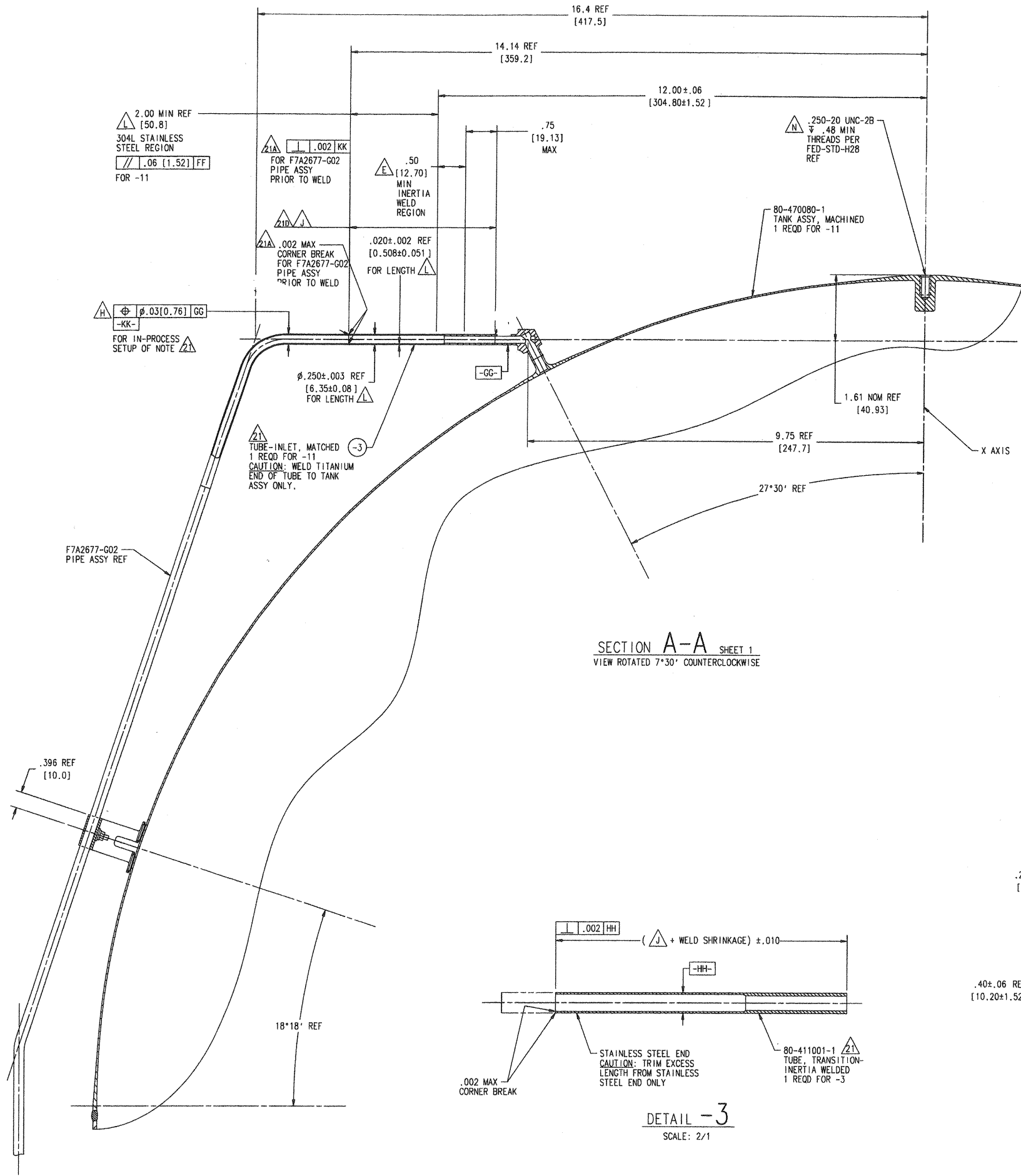

SECTION A-A SHEET 1  
VIEW ROTATED 7°30' COUNTERCLOCKWISE

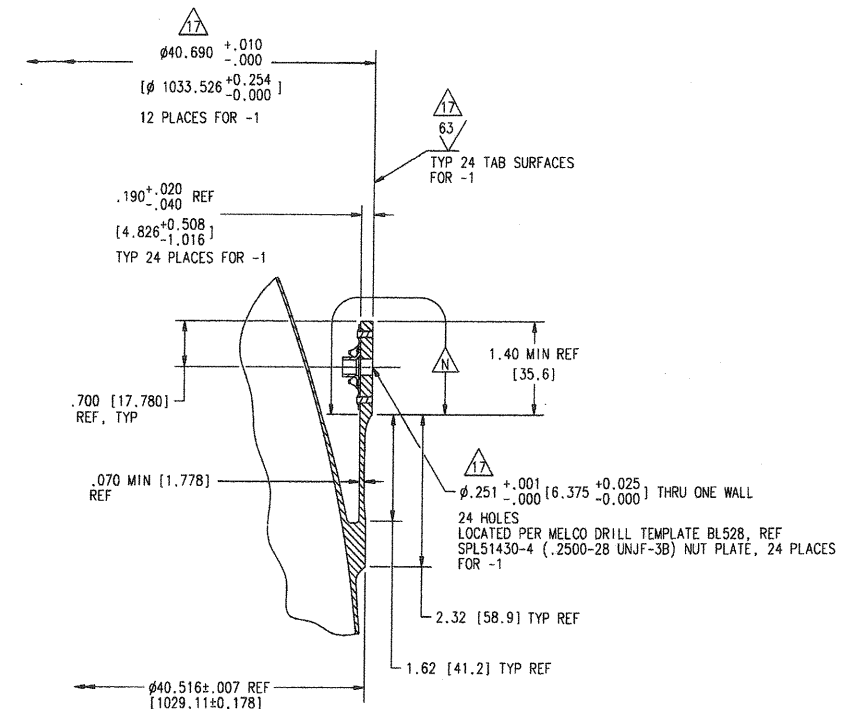

SECTION J-J SHEET 1  
BACKGROUND GEOMETRY OMITTED FOR CLARITY

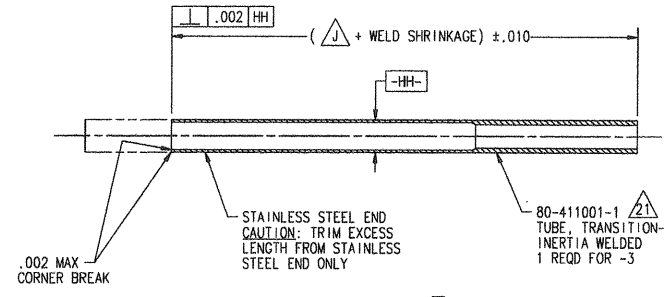

DETAIL -3  
SCALE: 2/1

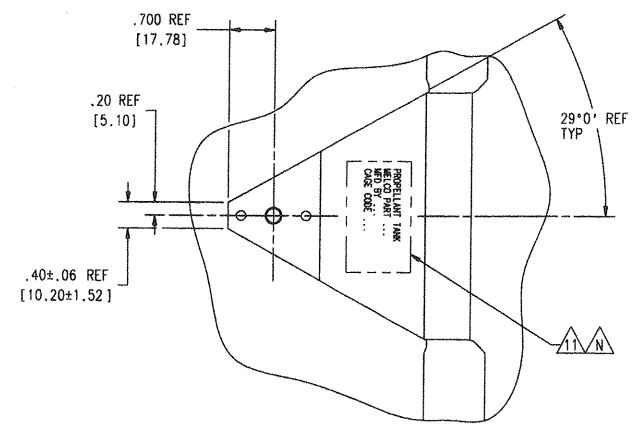

VIEW U SHEET 1

PRESSURE SYSTEMS, INC. LOS ANGELES, CALIFORNIA			
PROPELLANT TANK ASSY			
CAGE CODE 18229	SIZE E	ENG. NO. 80470	REV. A
SCALE: 1/1		SHEET 3 OF 3	